

SLUICE GATE WALL MOUNTED

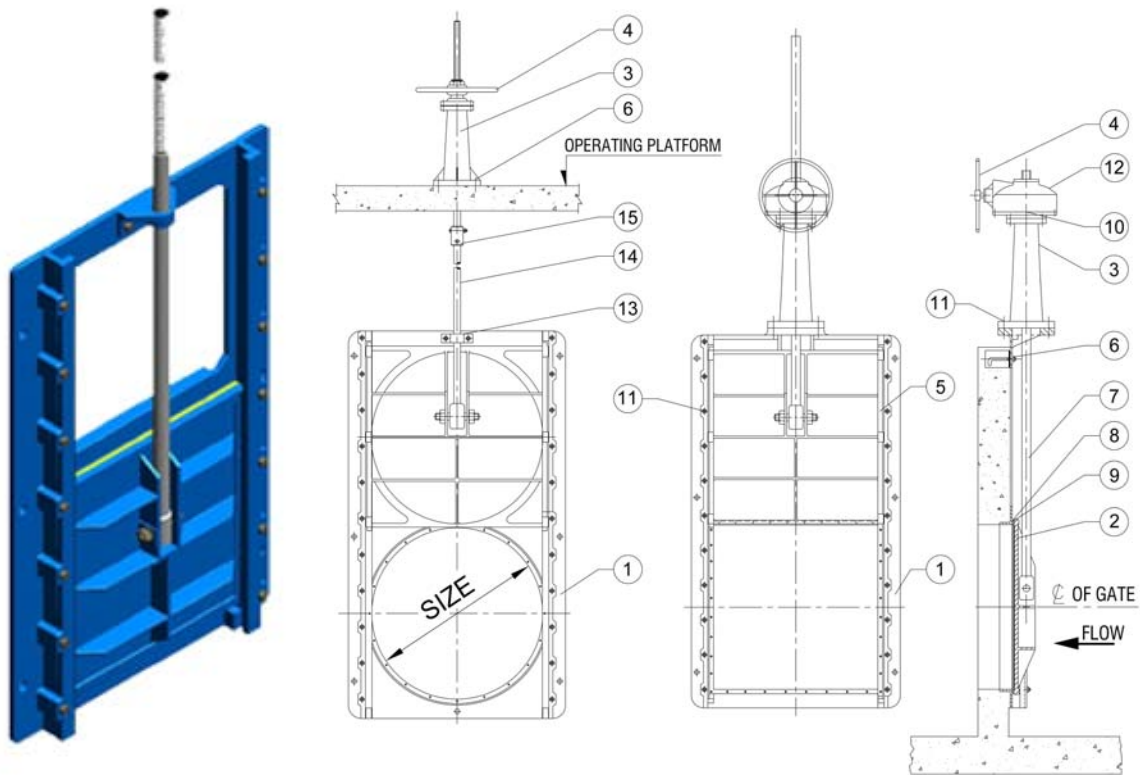

SL. No.	DESCRIPTION	MATERIAL
1	GATE FRAME	C.I.
2	DOOR	C.I.
3	HEAD STOCK	C.I.
4	HAND WHEEL	C.I.
5	GUIDE STRIP	C.I.
6	ANCHOR BOLTS	CARBON STEEL
7	SPINDLE	STAINLESS STEEL
8	FRAME FACE SEAT	LT BRONZE / SS
9	DOOR FACE SEAT	LT BRONZE / SS
10	OPERATING LIFT NUT	LT BRONZE / SS
11	FASTENERS	CARBON STEEL / SS
12	BEVEL GEAR UNIT	MFR'S STD
13	SPINDLE GUIDE	C.I. / M.S.
14	EXTENSION ROD	M.S. / S.S.
15	COUPLING	M.S. / S.S.

DESIGN FEATURES	
SIZE RANGE	CIRCULAR: 200 MM TO 1200 MM. OTHER ANY SIZE ON REQUEST SQUARE: 200 MM TO 1200 MM. OTHER ANY SIZE ON REQUEST RECTANGULAR: 300 MM X 375 MM TO 1200 MM X 1050 MM. OTHER ANY SIZE ON REQUEST
TYPE	RISING / NON RISING
CLASS	CL-1, CL-2, CL-3
DESIGN STANDARD	IS: 3042
MATERIAL	CI
OPERATION	MANUAL / GEAR / ELEC.ACTUATOR / PNEUMATIC / CHAIN PULLY