

PRESSURE RELIEF VALVE

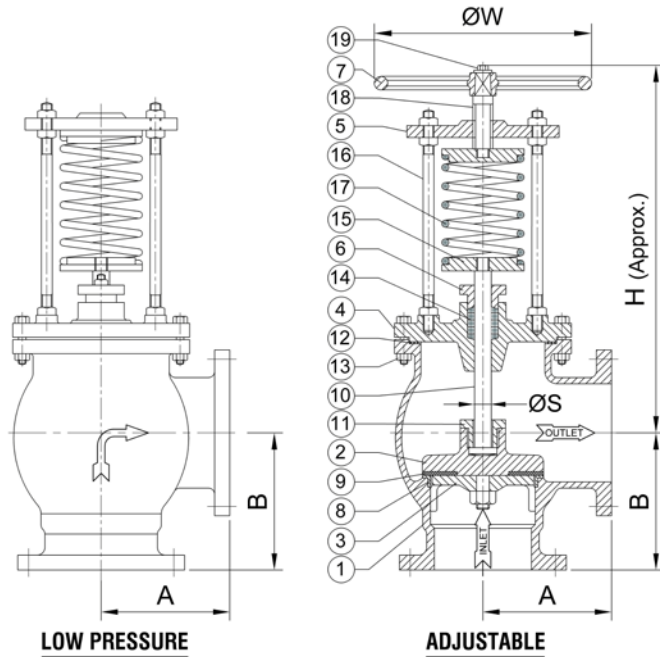

MATERIALS OF CONSTRUCTIONS

SL. No.	DESCRIPTION	MATERIAL
1	BODY	C.I. / D.I. / C.S.
2	VALVE DISC	C.I. / D.I. / C.S.
3	VALVE DISC HOLDER	C.I. / D.I. / C.S.
4	COVER	C.I. / D.I. / C.S.
5	CROSS HEAD	C.I. / D.I. / C.S.
6	GLAND	C.I. / D.I. / C.S.
7	HAND WHEEL	C.I. / D.I. / C.S.
8	BODY SEAT	L.T.BRONZE
9	DISC SEAT	RUBBER / L.T.BRONZE
10	STEM	SS 410 / 304 / 316 / 431
11	DISC LOCK NUT	SS 410 / 304 / 316 / 431
12	GASKET	RUBBER
13	BOLTS & NUTS	CARBON STEEL
14	GLAND PACKING	JUTE & HEMP
15	SPRING HOLDER	MILD STEEL
16	PILLER STUDS & NUTS	CARBON STEEL
17	SPRING	SPRING STEEL
18	STAY ROD	CARBON STEEL
19	SET SCREW	CARBON STEEL

DESIGN FEATURES	
SIZE RANGE	50 MM TO 300 MM
PRESSURE RATING	10Kg/cm ²
DESIGN STANDARD	'G&K'CAT, Fig H-19
FLANGE ENDS	BS / IS / ANSI / DIN
MATERIAL	CI / DI / CS

SL. No.	SIZE	A	B	H	ØS	ØW
1	50 MM	120	115	375	24	175
2	65 MM	127	127	400	24	175
3	80 MM	140	140	425	24	175
4	100 MM	178	459	470	26	200
5	125 MM	203	185	535	26	200
6	150 MM	229	203	585	28	225
7	200 MM	254	254	670	30	225
8	250 MM	292	305	790	32	275
9	300 MM	330	355	895	36	355

ALL DIMENSIONS ARE IN MM.