

SLANTED SEATED CHECK VALVE

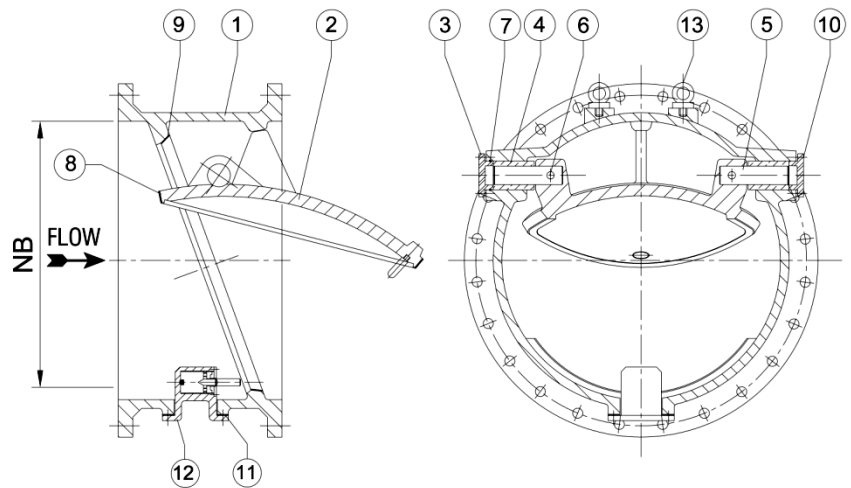

SL. No.	DESCRIPTION	MATERIAL
1	BODY	CI / DI / WCB / CF8 / CF8M
2	DISC	CI / DI / WCB / CF8 / CF8M
3	RETAINER	CI / DI / WCB / CF8 / CF8M
4	BEARING BUSH	LT BRONZE
5	SHAFT	SS 410
6	DOWEL PIN	SS 410
7	RUBBER 'O' RING	EPDM RUBBER (SHORE HARDNESS 65±5)
8	BODY SEAT FACING	LTB 2 / SS / NICKEL WELD OVERLAY
9	DISC SEAT FACING	LTB 2 / SS / NICKEL WELD OVERLAY
10	EXTERNAL FASTENERS	CARBON STEEL
11	GASKET	RUBBER
12	DAMPER UNIT	MFR'S STD.
13	LIFTING EYE BOLT	CARBON STEEL

DESIGN FEATURES	
SIZE RANGE	200 mm to 1000 mm
PRESSURE RATING	PN 1.0, PN 1.6, PN 2.0 & PN 2.5
DESIGN STANDARD	AS PER DVPL DESING
TESTING STANDARD	AS PER DVPL / CLIENT
FLANGE STANDARD	BS / IS / ANSI / DIN
MATERIAL	CI / DI / WCB / CF8 / CH8M

HYDROSTATIC TEST PRESSURE (Kg/Cm ²)		
RATING	BODY	SEAT
PN 1.0	15	10
PN 1.6	24	16
PN 2.0	30	20
PN 2.5	38	25

DIMENSION TABLE

SL. No.	SIZE	FACE TO FACE	FLANGE DIA	FLANGE THICKNESS	PCD	NO. OF HOLE	HOLE DIA

ALL DIMENSIONS ARE IN MM.