

SINGLE DOOR NON RETURN VALVE

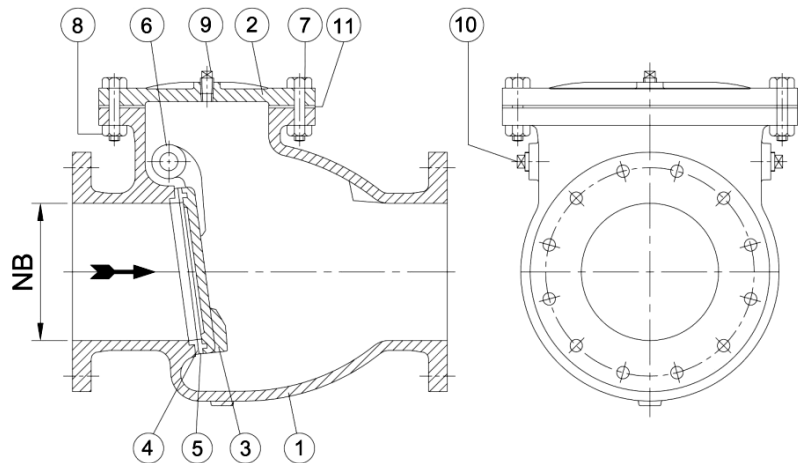

SL. No.	DESCRIPTION	MATERIAL
1	BODY	CI / DI / CS
2	COVER	CI / DI / CS
3	DISC WITH HINGE	CI / DI / CS
4	BODY SEAT RING	LT BRONZE / RUBBER / SS304 / 316 NICKEL WELD OVERLAY
5	DISC FACING RING	LT BRONZE / RUBBER / SS304 / 316 NICKEL WELD OVERLAY
6	HINGE PIN	SS: 410 / 304 / 316 / 431 / IS: 6603
7	COVER BOLTS / STUDS	CARBON STEEL
8	COVER NUTS	CARBON STEEL
9	AIR RELEASE PLUG	CARBON STEEL
10	SIDE PLUG	CARBON STEEL
11	GASKET	RUBBER

DESIGN FEATURES	
SIZE RANGE	50 mm to 600 mm
PRESSURE RATING	PN 1.0, PN 1.6 & PN 2.0
DESIGN STANDARD	IS: 5312 Part-1, BS: 1868, AWWA C508
TESTING STANDARD	IS: 5312, API 598
FLANGE STANDARD	BS / IS / ANSI / DIN
MATERIAL	CI / DI / CS / SS
ACCESSORIES	By-pass arrangement

HYDROSTATIC TEST PRESSURE (Kg/Cm ²)		
RATING	BODY	SEAT
PN 1.0	15	10
PN 1.6	24	16
PN 2.0	30	20

DIMENSION TABLE

SL. No.	SIZE	FACE TO FACE	FLANGE DIA	FLANGE THICKNESS	PCD	NO. OF HOLE	HOLE DIA

ALL DIMENSIONS ARE IN MM.