

DUEL PLATE CHECK VALVE

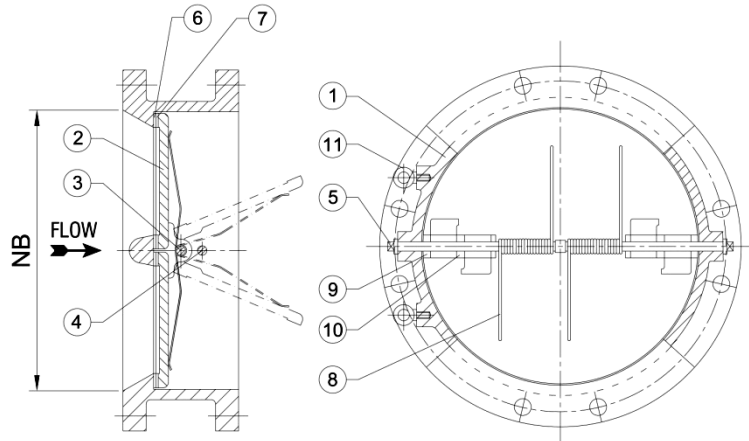

SL. No.	DESCRIPTION	MATERIAL
1	BODY	CI / DI / WCB / CF8 / CF8M
2	DISC / PLATE	DI / WCB / CF8 / CF8M
3	HINGE PIN	SS 410 / 304 / 316 / 431
4	STOP PIN	SS 410 / 304 / 316 / 431
5	PLUG	CARBON STEEL
6	BODY SEAT	LTB-2 / SS / NICKEL WELD OVERLAY
7	DISC SEAT FACING	EPDM / SS / NICKEL WELD OVERLAY
8	SPRING	STAINLESS STEEL
9	BODY LUG BEARING	LT BRONZE / SS
10	DISC LUG BEARING	LT BRONZE / SS
11	LIFTING HOOK (ABOVE 200 NB)	CARBON STEEL

DESIGN FEATURES	
SIZE RANGE	500 mm to 2000 mm
PRESSURE RATING	PN 1.0, PN 1.6
DESIGN STANDARD	API 594 / API 6D
TESTING STANDARD	API 598
FLANGE STANDARD	BS / IS / ANSI / DIN
MATERIAL	CI / DI / CS / SS

HYDROSTATIC TEST PRESSURE (Kg/Cm ²)		
RATING	BODY	SEAT
PN 1.0	15	10
PN 1.6	24	16

DIMENSION TABLE

SL. No.	SIZE	FACE TO FACE	FLANGE DIA	FLANGE THICKNESS	PCD	NO. OF HOLE	HOLE DIA

ALL DIMENSIONS ARE IN MM.