

# CAST STEEL GATE VALVE

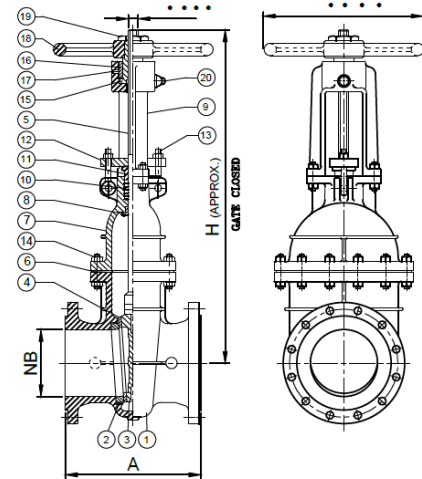
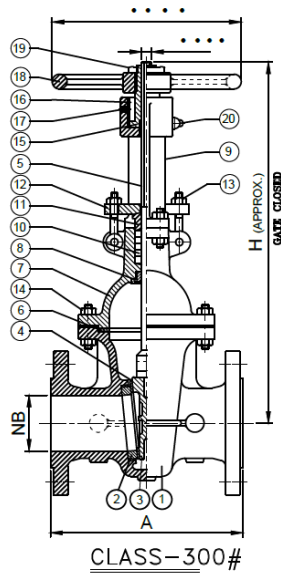

## MATERIALS OF CONSTRUCTIONS

| SL. No. | DESCRIPTION        | MATERIAL                                                         |
|---------|--------------------|------------------------------------------------------------------|
| 1       | BODY               | WCB / LCB / CF8 / CF8M                                           |
| 2       | BODY SEAT          | SS 410 / 304 / 316                                               |
| 3       | WEDGE              | WCB / LCB / CF8 / CF8M                                           |
| 4       | WEDGE SEAT FACING  | 13% Cr, OVERLAY ON WCB / CA-15 / CF8 / CF8M                      |
| 5       | STEM               | SS 410 / 304 / 316                                               |
| 6       | GASKET             | RUBBER / SP.WOUND-SS-304-ASB / GRAPH.FILLER                      |
| 7       | BONNET             | WCB / LCB / CF8 / CF8M                                           |
| 8       | BACK SEAT          | SS 410 / 304 / 316                                               |
| 9       | YOKE               | WCB / LCB / CF8 / CF8M                                           |
| 10      | GLAND PACING       | MACHINE BRAIDED METALLIC WIRE REINFORCEMENT ASB / GRAFOIL / PTFE |
| 11      | GLAND              | SS 410 / 304 / 316                                               |
| 12      | GLAND FLANGE       | WCB / LCB / CF8 / CF8M                                           |
| 13      | EYE BOLTS & NUTS   | ASTM A193, Gr B7 & A194, Gr.2H / SS-304                          |
| 14      | STUDS & NUTS       | ASTM A193, Gr B7 & A194, Gr.2H / SS-304                          |
| 15      | SLEEVE BUSH        | CARBON STEEL / TB                                                |
| 16      | S. BUSH LOCK NUT   | CARBON STEEL / SS-304                                            |
| 17      | GRUB SCREW         | CARBON STEEL / SS-304                                            |
| 18      | HAND WHEEL         | MS / DI / WCB                                                    |
| 19      | WHEEL LOCK NUT     | CARBON STEEL / SS-304                                            |
| 20      | GREASE NIPPLE PLUG | COMMERCIAL                                                       |

## DESIGN FEATURES

|                  |                            |
|------------------|----------------------------|
| SIZE RANGE       | 50 MM TO 450 MM            |
| PRESSURE RATING  | CLASS-150#, CLASS-300#     |
| DESIGN STANDARD  | BS 1873                    |
| FLANGE ENDS      | ASME B16.5                 |
| MATERIAL         | WCB / LCB / CF8 / CF8M     |
| TESTING STANDARD | API 598                    |
| ASSESSORIES      | GEAR, ACTUATOR, HEAD STOCK |

## HYDROSTATIC TEST PRESSURE (Kg/Cm<sup>2</sup>)

| RATING     | BODY | SEAT |
|------------|------|------|
| CLASS-150# | 32   | 22   |
| CLASS-300# | 79   | 57   |

## DIMENSION TABLE

| SL. No. | SIZE   | FACE TO FACE | FLANGE DIA | FLANGE THICKNESS | R.F. DIA | R.F. THIK | PCD   | NO. OF HOLE | HOLE DIA |
|---------|--------|--------------|------------|------------------|----------|-----------|-------|-------------|----------|
| 1       | 50 MM  | 178          | 150        | 19.5             | 92       | 2         | 120.7 | 4           | 19       |
| 2       | 65 MM  | 190          | 180        | 21.7             | 105      | 2         | 139.7 | 4           | 19       |
| 3       | 80 MM  | 203          | 190        | 24.3             | 127      | 2         | 152.4 | 4           | 19       |
| 4       | 100 MM | 229          | 230        | 24.3             | 157      | 2         | 190.5 | 8           | 19       |
| 5       | 125 MM | 254          | 255        | 24.3             | 186      | 2         | 215.9 | 8           | 22.2     |
| 6       | 150 MM | 267          | 280        | 25.9             | 216      | 2         | 241.3 | 8           | 22.2     |
| 7       | 200 MM | 292          | 345        | 29               | 270      | 2         | 298.5 | 8           | 22.2     |
| 8       | 250 MM | 330          | 405        | 30.6             | 324      | 2         | 362   | 12          | 25.4     |
| 9       | 300 MM | 356          | 485        | 32.2             | 381      | 2         | 431.8 | 12          | 25.4     |
| 10      | 350 MM | 381          | 535        | 35.4             | 413      | 2         | 476.3 | 12          | 28.6     |
| 11      | 400 MM | 406          | 595        | 37               | 470      | 2         | 539.8 | 16          | 28.6     |
| 12      | 450 MM | 432          | 635        | 40.1             | 533      | 2         | 577.9 | 16          | 31.8     |
| 13      | 500 MM | 457          | 700        | 43.3             | 584      | 2         | 635   | 20          | 31.8     |
| 14      | 600 MM | 508          | 815        | 48.1             | 692      | 2         | 749.3 | 20          | 35       |

ALL DIMENSIONS ARE IN MM.