

# FOOT VALVE

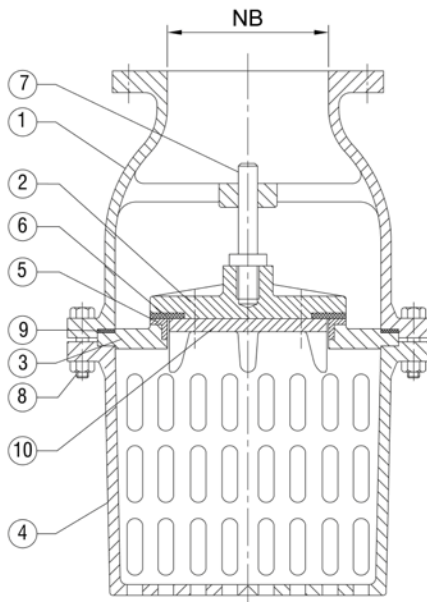

LIFT TYPE FOOT VALVE

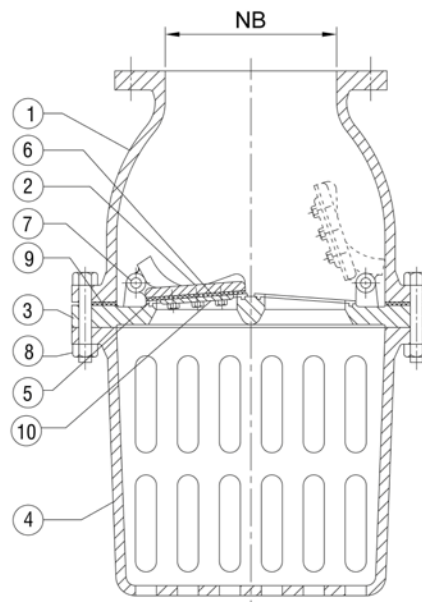

SWING TYPE FOOT VALVE

## MATERIALS OF CONSTRUCTIONS

SL. No.	DESCRIPTION	MATERIAL
1	BODY	C.I. / D.I.
2	DISC	C.I. / D.I.
3	DISPHRAGM	C.I. / D.I.
4	STRAINER	C.I. / D.I.
5	FACE SEAT	L.T. BRONZE
6	DISC SEAT / SEAL	NATURAL / SYNTHETIC RUBBER
7	GUIDE PIN	S.S.
8	BOLTS & NUTS	IS: 1367 CL-4.6 & 4.0
9	GUIDE PIN	S.S.
10	DISC SEAT HOLDER	C.I. / D.I. / G.I.

## DESIGN FEATURES

SIZE RANGE	25 MM TO 450 MM
PRESSURE RATING	HOUSING – 6Kg/cm <sup>2</sup> (g) & SEAT – 2Kg/cm <sup>2</sup> (g)
DESIGN STANDARD	IS: 4038
FLANGE ENDS	BS / IS / ANSI / DIN
MATERIAL	CI / DI