

TRIPLE FUNCTION TAMPERPROOF

AIR RELEASE VALVE

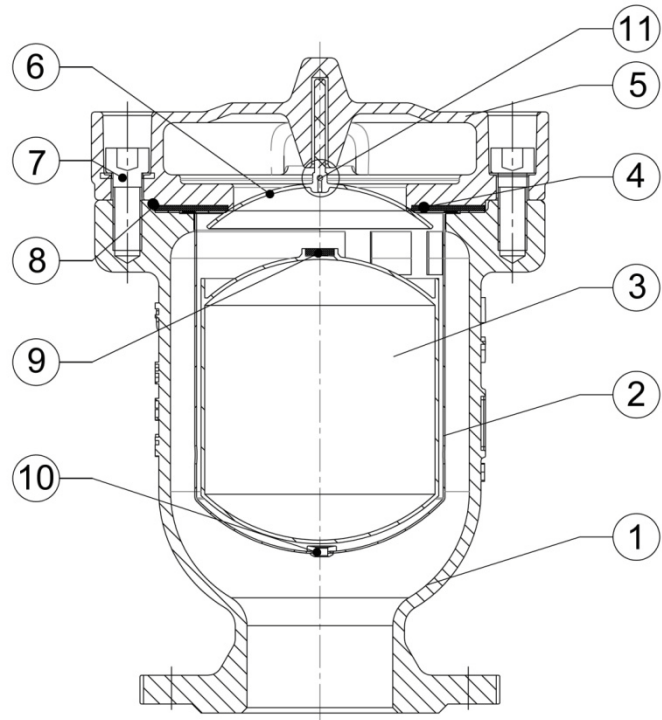

MATERIALS OF CONSTRUCTIONS

SL. No.	DESCRIPTION	MATERIAL
1	BODY	DUCTILE IRON
2	GUIDE BARREL	STAINLESS STEEL
3	FLOAT	STAINLESS STEEL
4	SEAT	NITRILE RUBBER
5	BONNET	DUCTILE IRON
6	SEALING ARC	STAINLESS STEEL
7	BOLT	STAINLESS STEEL
8	O-RING	RUBBER
9	NOZZLE	RUBBER
10	BUFFER	RUBBER
11	SMALL NOZZLE	STAINLESS STEEL

DESIGN FEATURES	
SIZE RANGE	50 MM TO 300 MM
PRESSURE RATING	PN 1.0, PN 1.6, PN 2.0, PN 2.5
DESIGN STANDARD	AWWA C-512
TESTING STANDARD	IS: 14845
FLANGE STANDARD	BS / IS / ANSI / DIN
MATERIAL	DUCTILE IRON

HYDROSTATIC TEST PRESSURE (Kg/Cm ²)		
RATING	BODY	SEAT
PN 1.0	15	10
PN 1.6	24	16
PN 2.0	30	20
PN 2.5	38	25

DIMENSION TABLE

SL. No.	SIZE	HEIGHT	FLANGE DIA	FLANGE THICKNESS	PCD	NO. OF HOLE	HOLE DIA
1	50 MM	298	165	19	125	4	19
2	80 MM	323	200	19	160	4	19
3	100 MM	396	220	19	180	8	19
4	150 MM	425	285	19	240	8	23
5	200 MM	542	340	20	295	8	23
6	300 MM	665	460	24.5	410	12	23

ALL DIMENSIONS ARE IN MM.