

TAMPER PROOF DOUBLE ACTING AIR VALVE (AWWA C-512)

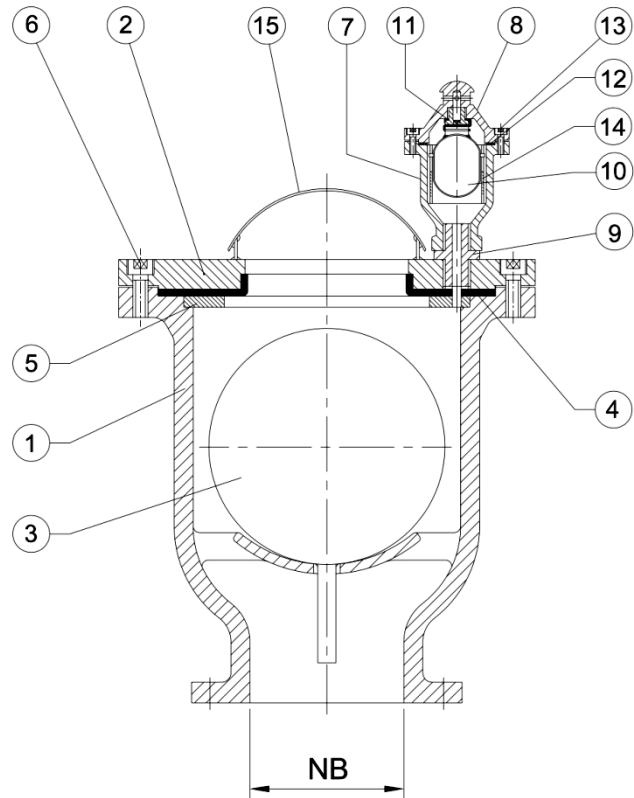

SL. No.	DESCRIPTION	MATERIAL
1	BODY (ARV)	CI / DI / SS
2	COVER	CI / DI / SS
3	LARGE ORIFIC FLOAT	CI / DI / SS
4	GASKET (JOINT RING)	CI / DI / SS
5	JOINT SUPPORT RING	CI / DI / SS
6	SOCKET HEAD BOLTS	NATURAL RUBBER
7	BODY	LT BRONZE / SS
8	COVER	SOFT RUBBER COAQTED SEASONED TIMBER / SS
9	SMALL ORIFIC FLOAT	HARD VULCANITE COATED SEASONED TIMBER / SS
10	SMALL ORIFIC PLUG	NATURAL RUBBER
11	GASKET (JOINT RING)	CARBON STEEL / SS
12	BOLTS / STUDS & NUTS	CARBON STEEL / SS
13	GUIDE FOR SMALL ORIFICE FLOAT	P.V.C.
14	COWL	G.I.

DESIGN FEATURES	
SIZE RANGE	40 mm to 400 mm
PRESSURE RATING	PN 1.0, PN 1.6
DESIGN STANDARD	AWWA C-512
TESTING STANDARD	IS: 14845
FLANGE ENDS	BS / IS / ANSI / DIN
MATERIAL	CI / DI / SS

HYDROSTATIC TEST PRESSURE (Kg/Cm ²)		
RATING	BODY	SEAT
PN 1.0	15	10
PN 1.6	24	16

*Attached separate dimension table.