

AIR VACCUM VALVE

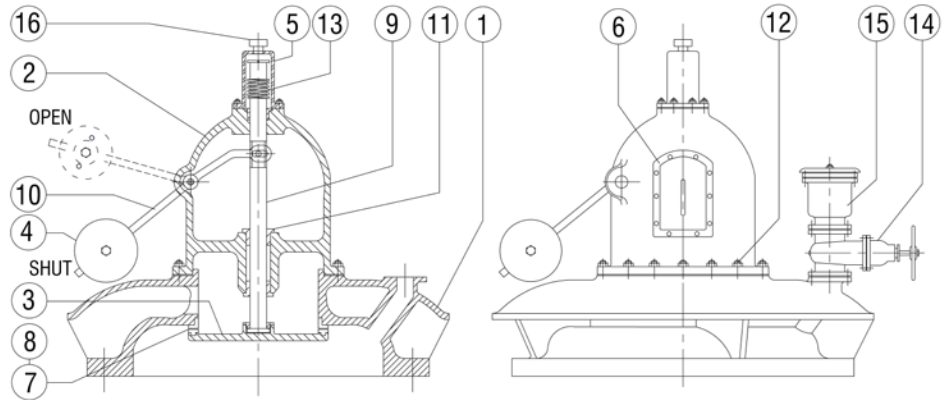

MATERIALS OF CONSTRUCTIONS

SL. No.	DESCRIPTION	MATERIAL
1	BODY	D.I. / C.S.
2	DOME	D.I. / C.S.
3	DISC	D.I. / C.S.
4	COUNTER WEIGHT	C.I. / M.S. FAB
5	TOP COVER	S.S. / M.S. GALVD.
6	INSPECTION DOOR	S.S. / M.S. GALVD.
7	DISC FACING RING	L.T. BRONZE
8	BODY SEAT RING	L.T. BRONZE
9	GUIDE PIN	S.S.
10	LEVER	FORGED STEEL
11	BUSH	BRASH
12	STUDS / BOLTS & NUTS	CARBON STEEL
13	SPRING	SPRING STEEL
14	SLUICE VALVE UNIT	D.I. / C.S. (AS PER IS: 14846)
15	KINETIC AIR VALVE	D.I. / C.S. (AS PER IS: 14845 DK)
16	OIL CAP	-

DESIGN FEATURES

SIZE RANGE	300 MM TO 800 MM
PRESSURE RATING	10 Mpa TO 20 Mpa
DESIGN STANDARD	DVPL Design
FLANGE ENDS	BS / IS / ANSI / DIN
MATERIAL	DI / CS